

Harmonic Aspects of Offshore Wind Farms

L. H. Kocewiak, C. L. Bak and J. Hjerrild

ABSTRACT

THIS paper presents the aim, the work and the findings of a PhD project entitled “Harmonics in Large Offshore Wind Farms”. It focuses on the importance of harmonic analysis in order to obtain a better performance of future wind farms. The topic is investigated by the PhD project at Aalborg University (AAU) and DONG Energy. The objective of the project is to improve and understand the nature of harmonic emission and propagation in wind farms (WFs), based on available information, measurement data and simulation tools. The aim of the project is to obtain validated models and analysis methods of offshore wind farm (OWF) systems.

I. INTRODUCTION

The number of variable speed wind turbines (WT) with advanced power electronic converters in the MW range used in large OWF is rapidly increasing [1]. More and more WT manufacturers such as General Electric (GE) Energy, Siemens Wind Power, Vestas Wind Systems or Gamesa use back-to-back converters in their flagship products [2], [3]. Nowadays, OWFs are connected through a widespread MV submarine cable network and connected to the transmission system by long HV cables. This represents new challenges to the industry in relation to understanding the nature, propagation and effects of harmonics [4].

Nowadays, variable-speed WTs are grid friendly machines in most power quality respects. The power electronic devices with advanced semiconductor technology and advanced control methods that are used in WTs for transferring power from the generator to the grid can meet the most demanding grid requirements seen today. However, there are issues with regard to the power quality, voltage stability, transmission

losses, and reliability that need to be addressed and improved in order to exploit the potential and advantages that large OWFs have as important elements in the efforts to reach renewable energy targets while maintaining a stable and robust power system.

A. Nowadays wind farms

WT performance is a critical issue in light of increasingly stringent grid connection requirements. These days, modern wind farms provide a sophisticated set of grid code friendly features. This is achieved by using sophisticated WF control systems for integrating external control signals, measurements, the control systems of the individual wind turbines, and centralised units such as park transformers, SVCs etc. The full-scale converter WTs concept is an important technological advantage to reduce constraints as far as the fulfilment of grid code requirements is concerned. Technology provided by most WT manufacturers can support the grid through reactive power supply, and it can be operated similar to a conventional power plant. Additionally, with the reactive power feature, the WTs in the MW power capacity range can generate reactive power even when the wind is not blowing, which can be exploited for providing reactive power to the system and for fast response voltage stabilisation, which would otherwise have to be provided by other units in the system.



Fig. 1 Wind turbines from Burbo Bank Offshore Wind Farm (daylife.com).

The Industrial Ph.D. project “Harmonics in Large Offshore Wind Farms” supported by the Danish Ministry of Science, Technology and Innovation, project number 08-044839, and DONG Energy Power, Electrical Power Systems and Analysis.

L. H. K. is a PhD student at the Institute of Energy Technology, Aalborg University, 9220 Aalborg, Denmark (e-mail: lukko@dongenergy.dk, phone no. +45 99 55 78 51).

C. L. B. is with Institute of Energy Technology, Aalborg University, 9220 Aalborg, Denmark (clb@iet.aau.dk).

J. H. is with DONG Energy Power, Skærbæk, 7000 Fredericia, Denmark (e-mail: jeshf@dongenergy.dk, phone no. +45 99 55 29 89).

Paper submitted to the PhD Seminar on Detailed Modelling and Validation of Electrical Components and Systems 2010 in Fredericia, Denmark, February 8th, 2010

In recent years, power systems in the whole world have experienced a significant increase in dispersed generation units (DGUs), and especially wind energy penetration. Presently, the trend is for planning large WFs with a capacity of hundreds of MVA. This large-scale utilization of wind energy has caused an increasing concern about its influence on the power quality of the power system [5].

Commonly applied in WTs power electronic devices, transferring power from the generator to the grid, are able to meet the most demanding grid requirements. The latest

achievements in semiconductor technology and control methods of wt converters contribute to improve power quality obtained from modern wind power plants, enhanced voltage stability [6], [7]. Reduced transmission losses and reliability improvement are the most important virtues of dispersed power generation sources. Those advantages create a bright future for the wind power industry.

B. Harmonic aspects in offshore wind farms

Harmonics generated by the grid-side power converters may be of concern in networks where harmonic resonance conditions may exist in large OWFs with a widespread submarine MV cable network connected to the transmission system by long HV underground cables [8]. Submarine power cables, unlike underground land cables, need to be heavily armoured and are consequently complicated structures, having many concentric layers of different materials. Inductive coupling across the material boundaries contribute to the overall cable impedance, and these complex relationships consequently affect the level of voltage and current waveform distortion and amplification due to possible resonances, as the electrical characteristic of cables in the frequency domain is dependent on their geometrical arrangement and material layer structures [9]. In particular power cables have a relatively larger shunt capacitance compared to overhead lines which make them able to participate more in resonant scenarios.

The wind farm's internal impedance changes when the number of turbines in operation varies, and the resonant points vary as well. This becomes an important issue when a large offshore wind farm is taken into consideration. It shows the need to take into account the harmonic emission of wind farms for different configurations and emphasizes an importance to investigate every OWF system separately [8].

Large OWFs have a big influence on harmonic level in the point of common coupling and impact on the external network. The structure and number of turbines in operation do not seem to be so important for small onshore wind farms.

The design of subsea transmission scheme needs to include an assessment of waveform harmonic distortion and its interaction with the resonant frequencies of the transmission system. The large OWF connected to the transmission systems changes the frequency characteristic and therefore has an impact on the harmonic levels in the point of connection what in some cases can even improve the power quality. Without appropriate models it is impossible to reliably predict system resonances and the effects of any generated harmonics [10].

Consequently, it becomes necessary to study the different categories of resonance problems in more detail. An electrical transmission system can magnify harmonic voltages or harmonic currents with harmonics close to a resonance frequency [11].

This issue becomes quite complicated and makes accurate harmonic analysis of OWFs much more complex, involving advanced models for all system components, including the external HV network with consumer loads connected which present the greatest uncertainties [12]. In the case of small onshore dispersed wind farms (WFs) connected to the

distribution network, performing sophisticated harmonic load flow studies is not a usual practice due to the high number of such installations. For large OWFs, where the total capacity is in the range of hundreds of MW, harmonic load flow analysis becomes an important issue.

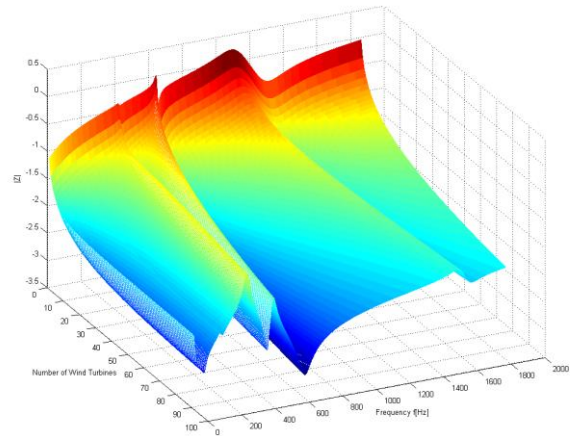

Fig. 2 Changes of an impedance absolute value in a large OWF due to a different number of WTs in operation.

II. HARMONIC ANALYSIS IN OFFSHORE WIND FARMS

When the waveform is non-sinusoidal but periodic with a period of one cycle of the power system frequency, current and voltage waveforms can be decomposed into a sum of harmonic components. For the voltage this can be mathematically expressed as

$$v(t) = V_0 + \sum_{h=1}^H V_h \sqrt{2} \cos(h\omega t - \gamma_h) \quad (1)$$

With $\omega = 2\pi f_0$ and f_0 the fundamental frequency or power system frequency: $f_0 = 1/T$ with T the (fundamental) period of the signal. In the same way, the current waveform can be expressed. The phase angle of the fundamental component of the voltage γ_1 can be set to zero without loss of generality [10].

Often the voltage or current waveform contains components that are not multiple integers of the power system frequency. Non-harmonic distortion (inter-harmonics and non-periodic distortion) is much harder to quantify through suitable parameters and it is regularly neglected. To measure these so-called inter-harmonics, it is necessary to measure over a longer period than one cycle. For this purpose classical harmonic analysis (ie harmonic power flow) becomes insufficient [11]. Another reason for neglecting non-harmonic distortion is that harmonic distortion dominates in most cases. Nowadays, where power electronic converter application in OWFs is significant, the extension of harmonic analysis becomes necessary.

For a voltage with only one inter-harmonic component, at frequency ζf_0 , it can be written

$$v(t) = V_0 + \sum_{h=1}^H V_h \sqrt{2} \cos(h\omega t - \gamma_h) + V_\xi \sqrt{2} \cos(\xi\omega t + \gamma_\xi) \quad (2)$$

Sub-harmonics are treated as a special case of inter-harmonic components, with frequencies less than power frequency, thus $\xi < 1$. Sub-harmonics are often analyzed separately and not taken into consideration in the harmonic analysis.

III. MEASUREMENT CAMPAIGNS

In order to determine harmonic emission level of an OWF as well as WT, appropriate measurements are needed. Measurement process for harmonic analysis purposes turns out a complex and not straightforward task. Harmonic assessment can be carried out based on long-term measurements, especially if probabilistic aspects of harmonic emission are considered [12]. The reliability and performance of equipment plays a crucial role during measurement process. A lot of aspects related with electromagnetic interference (EMI), sensor parameters, data acquisition (DAQ) board performance, aliasing phenomena, and logging devices efficiency have to be taken into consideration as well [12], [13].

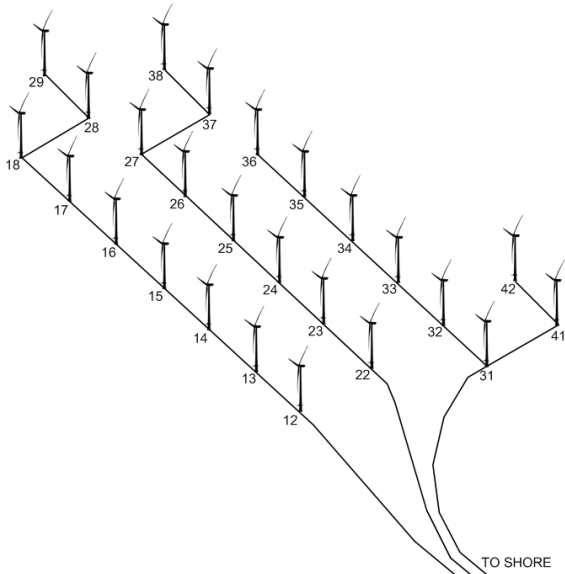

Fig. 3 The layout of Burbo Bank Offshore Wind Farm.

A. Burbo Bank Offshore Wind Farm

The measurement campaign at Burbo Bank Offshore Wind Farm (BBOWF) took place from the end of November 2007 to the beginning of February 2008. The BBOWF (Fig. 3) is located in shallow waters off the Burbo Flats in Liverpool Bay at the entrance to the River Mersey. It comprises 25 Siemens SWT-3.6-107 turbines with a rated power of 3.6 MW accounting for a total installed capacity of 90 MW. Voltages and currents were measured from both sides of a WT transformer as well as park transformer. Additionally, grounding transformer and capacitor bank electrical quantities were measured.

The measurements were carried out with a PC equipped with National Instruments DAQ card, ran by a programme developed in LabVIEW programming environment. Voltage and currents were sampled at 44.1 kHz, using NI PCI-4472 8-channel dynamic signal acquisition (DSA) board. Wind speed and digital signals were sampled at 5 Hz with NI PCI-6052E DAQ card. The DSA board has analogue filter to remove any signal components beyond the range of the analogue-to-digital converters (ADCs). To prevent high-frequency components, above half programmed sampling rate, from affecting the measured spectrum, an anti-aliasing filter was used. The anti-aliasing filter was an analogue low-pass filter that was placed before the analogue-digital (A/D) conversion. The described measurement setup is shown in Fig. 4.

B. Other measurement campaigns

Additional measurements must be carried out in order to precisely determine WT harmonic emission and the nature of emission propagation of harmonics in OWFs. To fulfil this task, GPS synchronised measurements will be carried out in different places inside an OWF. The harmonic spectrum of power converter and WT output will be analysed as well. The purpose is to measure all interesting electrical quantities of WT and OWF in steady-state operation.

The portable measurement set-up will be equipped with National Instruments DAQ card controlled by a software developed in LabVIEW environment. Voltage and currents will be sampled at 51.2 kS/s/ch in order obtain higher oversampling and improve the filtering process, using NI PXI-4472 8-channel DSA board. In order to compare results and efficiency of the anti-aliasing filter in which NI PXI-4472 is equipped, NI PXI-6133 multifunction DAQ device will be used for measurements as well. NI PXI-6682 timing and synchronisation board will be responsible for accurate triggering and GPS synchronisation.

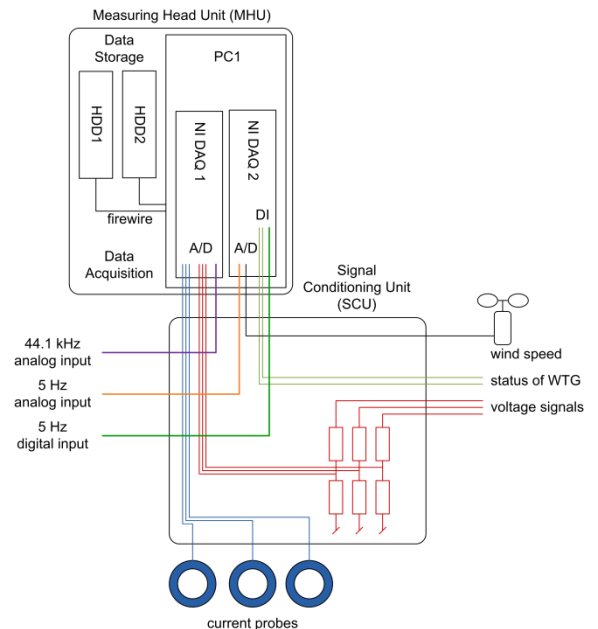

Fig. 4 DELTA powerLAB measuring system used in measurement campaign at Burbo Bank offshore wind farm.

In NI DSAs the analogue input circuitry uses oversampling

delta-sigma modulating ADCs. Delta-sigma converters are inherently linear, provide built-in brick-wall finite impulse response (FIR) anti-aliasing filters, and have specification which satisfies the most demanding requirements with regard to total harmonic distortion (THD), signal-to-noise ratio (SNR), and amplitude flatness. These features help to acquire signals with high accuracy and high fidelity without introducing noise or out-of-band aliases.

Additionally, the analogue filter is applied to remove higher frequency components near multiples of the oversampling rate which cannot be removed by digital filtering before they get to the sampler and the digital filter as it is shown in Fig. 5.

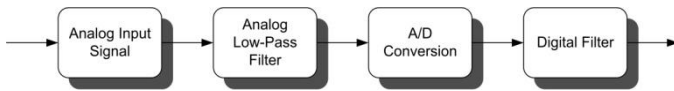

Fig. 5 Anti-aliasing filtering connected with A/D conversion.

The measurement set-up is equipped with high quality Rogowski type sensors with bandwidth up to 6.5 MHz and voltage probes with bandwidth up to 25 MHz.

IV. MEASUREMENT DATA PROCESSING

Analyzing the sampled voltage or current waveforms offers quantitative descriptions of power quality, such as the dominant harmonic components and their associated magnitudes [15]. If the measurement data (or block of the data) are stationary, frequency-domain decomposition of the data is often desirable. A standard and commonly preferred method is the discrete Fourier transforms (DFT) or its fast algorithm, the fast Fourier transform (FFT) [12].

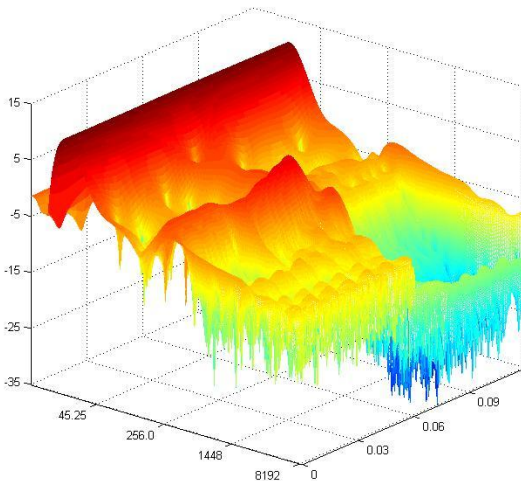

Fig. 6 Wavelet transform applied for non-stationary signals.

The harmonic voltages of OWFs normally result from the combination of emitted harmonic currents produced by nonlinear power converter devices and nonlinear passive components of the WF. Power converters are generally not fluctuating with significant correlation. Furthermore, quasi-stationary loads are also connected to the power system. Therefore, fast fluctuating harmonic voltage levels with a high

fluctuation magnitude are an exception and seldom occur in the OWF [8], [14].

However, strictly stationary signals do not exist in real-life WFs and power systems. Both small and big statistical changes occur in the electrical signal parameters. The presence of small and relatively slow statistical changes is addressed through so-called block-based methods [12]. The signal is assumed stationary over a short duration of time (or window), a so-called block of data. The signal features are estimated over this window. The size of the window is not arbitrarily defined and should be adjusted on the basis of experience and measurement data analysis [13]. Mainly the analysis is performed considering the base 10-cycle window harmonics, as suggested in IEC 61000-4-7 [15].

Note that it can be difficult in some occasions to judge whether a signal is stationary or non-stationary. To mathematically prove the stationarity requires the knowledge of the probability density function (PDF) of the signal and is therefore not a straightforward task.

V. PROBABILISTIC ASPECTS OF HARMONIC EMISSION

Stochastic aspects of WT harmonic emission have to be applied for WFs with power converters, and it is known that probabilistic techniques are helpful for evaluating the harmonic emission of a wind farm [16]. This is also aligned with the statistical approach adopted in the IEC 61000 series of electromagnetic compatibility (EMC) standards [17], where harmonic emission assessment refers to 95% non-exceeding probability values on the whole measurement period. The total harmonic emissions of a WF depend on the statistical characteristics of the individual WT harmonic current or voltage vectors. The probability distribution functions of their magnitudes and phase angles may prove very helpful in detailed harmonic studies

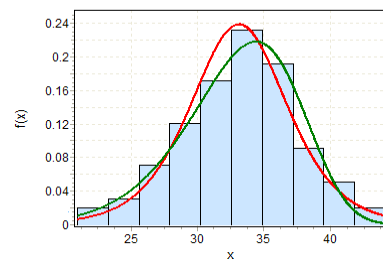

Fig. 7 Probability density functions fitting into a certain set of measurement data.

A typical approach to the harmonic analysis of a wind farm is to model the harmonic contribution of every WT by a harmonic current source. In most of cases, it is based on the IEC 61 400-21 standard [18] in which phase information is not available. The harmonic current that is fed into the system by a WT is typically assumed to be correlated with the harmonic order h . The problem with this approach is that the contribution of the different WTs is added up almost arithmetically what is not present in reality.

In order to determine harmonic emission of an OWF which has many degrees of freedom a Monte Carlo (MC) approach

becomes very helpful. MC methods are useful for modelling phenomena with significant uncertainty in inputs. The MC procedure requires the knowledge of PDFs of the input variables similar as in Fig. 7. For each random input datum, a value is generated according to its proper PDF. In order to deal with the summation of harmonics in WF, the knowledge of the statistical behaviour of the harmonic magnitudes and phase angles becomes very important. Nowadays phase information of harmonic content is not required in standards, but it can be directly obtained from the FFT for the harmonic current magnitudes. It should be emphasized that in contrast to harmonic magnitudes, phase errors increase significantly with harmonic order [19].

Basis of measurement data the random behaviour of harmonics must be investigated. Unfortunately in different WF configurations, harmonics behave in a different way. It is dependent on many aspects, such as WF production, loads, power converter control and operating point [20]. Complex interactions between all mentioned elements make impossible to assess harmonic emission in a deterministic way.

VI. PROJECT OBJECTIVES

The objectives of the PhD project are to provide in-depth knowledge of all relevant aspects related to harmonics in offshore wind farms including:

- The voltage source converter as a harmonic source
- Modelling and analysis of WTs and wind farm network elements in relation to harmonics (i.e., the frequency range from DC to 5kHz) in time and frequency domain
- Modelling of WT converters and other wind turbine components in time and frequency domain
- Interaction of offshore wind farms with AC transmission system (other harmonic sources, controllers, etc)
- Dynamic phenomena, ferroresonance, harmonic instability, period doublings, etc
- Operation of VSC with harmonic resonances near its characteristic frequency
- Engineering standards and power quality standards.

VII. CONCLUSION

The classical harmonic analysis in frequency domain, which is normally used for assessment of disturbances to the public grid, could be insufficient [21]. Lack of reliable models for power converters in relevant frequency range, manufacturer data are usually provided according to applicable standards [25], [15], [26] also contributes to obtaining insufficient results. This shows that it is necessary to define in standards appropriate WF components modelling.

It is necessary to extend data and models provided by manufacturers and to better describe modelling methods in standards. Modelling strategies for harmonic sources for power system harmonic analysis are sometimes insufficient. Simulation techniques in the frequency, time and harmonic domains and modelling of the wind turbines as harmonic sources should be extended. Finding a very good agreement between theory and experiment is necessary.

Power electronic converters for harmonic analysis can simply be represented by a harmonic current source suggested in standards or voltage source taking into consideration the nature of back-to-back as voltage source inverters. Both modelling cases give inappropriate results [22]. This creates a necessity to acquire new knowledge of power converters as a harmonic source. At present applied methods of full-scale converters modelling are insufficient in reference to standards and measurements.

Both IEEE [27], [27] and IEC [18], [26] standards consider harmonics in a general sense, without regard to characteristic harmonics generated by certain types of equipment or special operation modes. The project is focused on the extension of harmonic sources description in standards.

It is concluded that every WF system configuration should be investigated in cooperation with manufacturers which increases modelling complexity and difficulties. This problem is not only with reference to harmonic analysis, it exists in all branches of modelling. It shows the necessity to extend the requirements for data provided by manufacturers and to describe modelling methods better in standards.

VIII. REFERENCES

- [1] T. Ackerman, *Wind Power in Power Systems*. Wiley and Sons, 2005.
- [2] J. Birk and B. Andresen, "Parallel-connected converters for optimum reliability and grid performance in the Gamesa G10X 4.5 MW wind turbine," in *European Wind Energy Conference*, Brussels, 2008.
- [3] V. Akhmatov, J. Nygaard Nielsen, J. Thisted, E. Grøndahl, P. Egedal, M. Nørtoft Frydensbjerg, and K. Høj Jensen, "Siemens Windpower 3.6 MW Wind Turbines for Large Offshore Windfarms," in *Proc. 7th International Workshop on Large Scale Integration of Wind Power and on Transmission Networks for Offshore Wind Farms*, 26-27 May 2008, pp. 494-497.
- [4] W. Wiechowski and P. B. Eriksen, "Selected studies on offshore wind farm cable connections – challenges and experience of the Danish TSO," in *Proc. Power and Energy Society General Meeting – Conversion and Delivery of Electrical Energy in the 21st Century*, July 2008, pp. 1-8.
- [5] I. Arana, L. Kocewiak, J. Holbøll, C. L. Bak, A. H. Nielsen, A. Jensen, J. Hjerrild, and T. Sørensen, "How to improve the design of the electrical system in future wind power plants," in *Proc. Nordic Wind Power Conference*, Bornholm, 2009.
- [6] R. Jones, P. B. Brogan, E. Grøndahl, and H. Stiesdal, "Power Converters," U.S. Patent 7 372 174 B2, May 13, 2008.
- [7] J. I. Llorente Gonzales, B. Andersen, and J. Birk, "Methods for Operation of a Converter System," U.S. Patent 0 073 445 A1, Mar. 29, 2007.
- [8] S. A. Papathanassiou and M. P. Papadopoulos, "Harmonic Analysis in a Power System with Wind Generation," *IEEE Trans. Power Delivery*, vol. 21, no. 4, Oct. 2006.
- [9] C. H. Chien and R. W. G. Bucknall, "Theoretical Aspects of the Harmonic Performance of Subsea AC Transmission Systems for Offshore Power Generation Schemes," in *Proc. Generation Transmission and Distribution*, 2006, pp. 599-609.
- [10] N. R. Watson and J. Arrillaga, *Power System Harmonics*. Wiley and Sons, 2003.
- [11] G. J. Wakileh, *Systems Harmonics: Fundamentals, Analysis, and Filter Design*. Springer, 2001.
- [12] L. Kocewiak, J. Hjerrild, and C. L. Bak, "Harmonic analysis of offshore wind farms with full converter wind turbines," in *Proc. 7th International Workshop on Large Scale Integration of Wind Power and on Transmission Networks for Offshore Wind Farms*, 14-15 October 2009, pp. 539-544.
- [13] S. T. Tentzerakis, N. Paraskevopoulou, S. A. Papathanassiou, and P.

- Papadopoulos, "Measurement of wind farm harmonic emissions," in *Proc. IEEE Power Electronics Specialists Conference*, 15-19 June 2008, pp. 1769-1775.
- [14] M. H. Bollen and I. Gu, *Signal Processing of Power Quality Disturbances*. Wiley-IEEE Press, 2006.
- [15] M. Grabe, *Measurement Uncertainties in Science and Technology*. Springer, 2005.
- [16] A. Baghini, *Handbook of Power Quality*. Wiley and Sons, 2008.
- [17] S. T. Tentzerakis and S. A. Papathanassiou, "An Investigation of the Harmonic Emissions of Wind Turbines," *IEEE Trans. Energy Conversion*, vol. 22, pp. 150-158, Mar. 2007.
- [18] "Electromagnetic Compatibility (EMC) – Part 4-7: Testing and Measurement Techniques – General Guide on Harmonics and Interharmonics Measurements and Instrumentation, for Power Supply Systems and Equipment Connected Thereto," IEC 61000-4-7, August 2002.
- [19] J. Verboomen, R. L. Hendriks, Y. Lu, and R. Voelzk, "Summation of Non-Characteristic Harmonics in Wind Parks," in *Proc. Nordic Wind Power Conference*, Bornholm, 2009.
- [20] "Testing and measurement techniques – Power quality measurement methods," IEC 61400-4-30, 2008.
- [21] "Wind Turbine Generator Systems – Measurement and Assessment of Power Quality Characteristics of Grid Connected Wind Turbines," IEC 61400-21, 2008.
- [22] A. Cavallini, R. Langella, A. Testa, and F. Ruggiero, "Gaussian modeling of harmonic vectors in power systems," in *Proc. 8th International Conference on Harmonics And Quality of Power*, vol. 2, 14-18 October 1998, pp. 1010-1017.
- [23] A. Testa, D. Castaldo, and R. Langella, "Probabilistic aspects of harmonic impedances," in *Proc. Power Engineering Society Winter Meeting*, vol. 2, 2002, pp. 1076-1081.
- [24] Ł. Kocewiak, J. Hjerrild, and C. L. Bak, "Harmonic models of a back-to-back converter in large offshore wind farms compared with measurement data," in *Proc. Nordic Wind Power Conference*, Bornholm, 2009.
- [25] "Electromagnetic compatibility (EMC) – Part 2-12: Environment – Compatibility levels for low frequency conducted disturbances and signaling in public medium-voltage power supply systems," IEC 61000-2-12.
- [26] "Electromagnetic Compatibility (EMC) – Part 3: Limits – Section 6: Assessment of Emission Limits for Distorting Loads in MV and HV Power Systems – Basic EMC Publication," IEC 61000-3-6, 1996.
- [27] "IEEE Recommended Practices and Requirements for Harmonic Control in Electrical Power Systems," IEEE Standard 519-1992.

Lukasz Kocewiak was born in Grójec, Poland, in 1983. He received B.Sc. and M.Sc. degrees in electrical engineering from Warsaw University of Technology.

Currently he is an Industrial PhD student in cooperation with DONG Energy and Aalborg University. The main direction of his research is related with harmonics and nonlinear dynamics in power electronics and power systems.

Jesper Hjerrild was born in 1971. He received the M.Sc. and Ph.D. degrees in electrical engineering from the Technical University of Denmark, Lyngby, in 1999 and 2002, respectively.

Currently he has been employed at Dong Energy. His main technical interest is electrical power systems in general, involving a variety of technical disciplines including modelling of power system including wind power and power system control, stability and harmonics. Furthermore, he also works with designing of the wind farm

From 2002 until 2004 Jesper Hjerrild was employed at DEFU (The Association of Danish Energy Companies R&D).

Claus Leth Bak was born in Djursland, Denmark, in 1965. He received B. Sc. in Electrical Power Engineering from the engineering college in Århus in 1992, he received M.Sc. in Electrical Power Engineering in 1994.

He is an Associate Professor at Aalborg University with experience on high voltage engineering, relay protection for transmission systems and substation automation and dynamic analysis (PSCAD/EMTDC) of large power systems.